



REED-JOSEPH INTERNATIONAL COMPANY

TYPE 4 STORAGE MAGAZINE

ATF-APPROVED

ML802 WITH 2 HASPS AND 2 HOODS

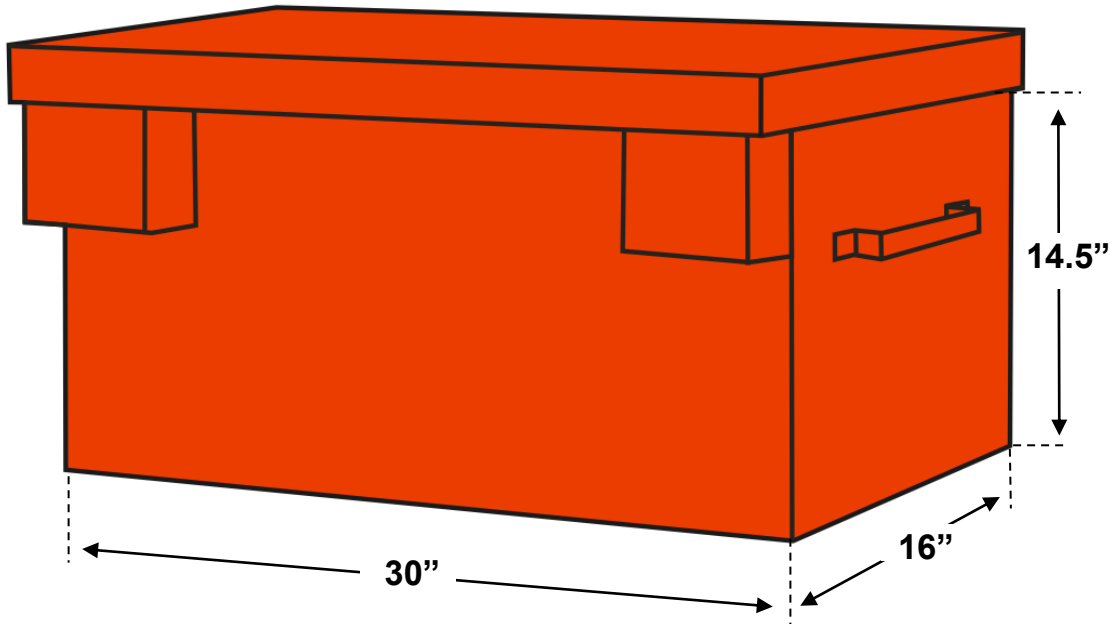

- EXTERIOR:** 18 gauge steel.
30" x 16" x 14.5".
- INTERIOR:** Lined with half inch plywood.
- LID:** 18 gauge steel, hinged to the box.
- HANDLE:** 0.25" plate handle.
- WEIGHT:** 90 lbs.
- VOLUME:** 3.70 cubic feet
- CAPACITY:** Including shipping packaging, it holds approximately
- 60 boxes of Bird Banger cartridges, *or*
 - 40 boxes of CAPA cartridges, *or*
 - 120 boxes of Screamer Siren cartridges.
- PADLOCKS:** ATF-approved, case hardened. 7/16" diameter shackle.
Has 5 tumblers. Padlocks are sold separately.